

TD1870 Multifunction Calibrator



1. Summary

TD1870 is a multi-function calibrator with wide range and high accuracy, integrates AC/DC voltage and current standard source, can output excellent DC\AC voltage, DC\AC current, DC\AC power, phase, frequency, and analog resistance etc. It's applied for calibrating 5.5 digits or less digital multimeters.

2. Features

- DC voltage output: $\pm(0 \sim 1020 \text{ V})$
- DC current output: $\pm(0 \sim 20.5 \text{ A})$
- AC voltage output: $1 \text{ mV} \sim 1020 \text{ V}$
- AC current output: $29 \mu\text{A} \sim 20.5 \text{ A}$
- Sinusoidal wave frequency: $10 \text{ Hz} \sim 500 \text{ kHz}$
- Simulated DC resistance: $0 \Omega \sim 1100 \text{ M}\Omega$
- 2 MHz square wave frequency output
- Phase output
- AC/DC power output
- Thermocouple output(optional)
- Thermal resistance output(optional)
- Clamp meter calibration (optional)

3. Application

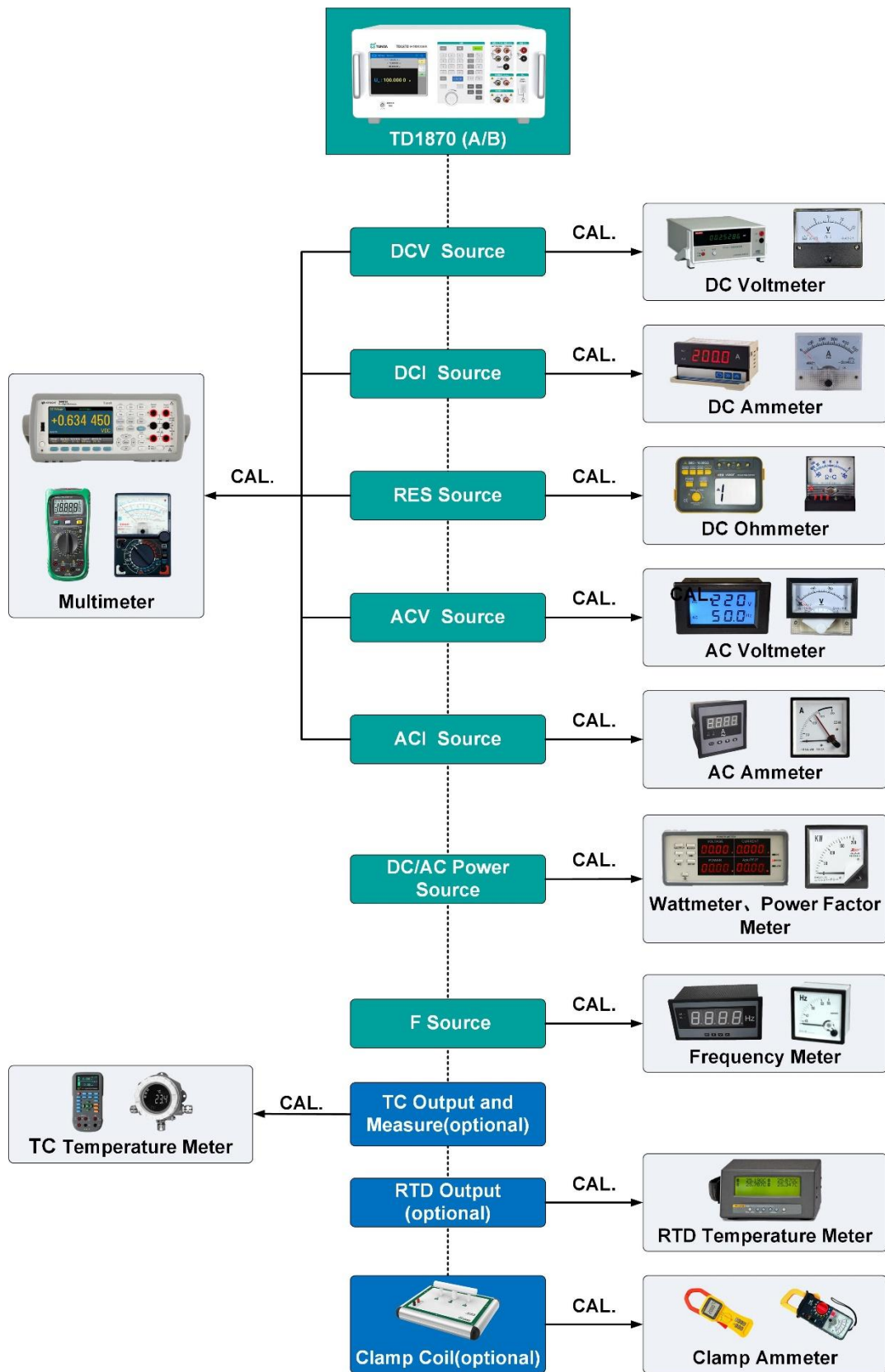

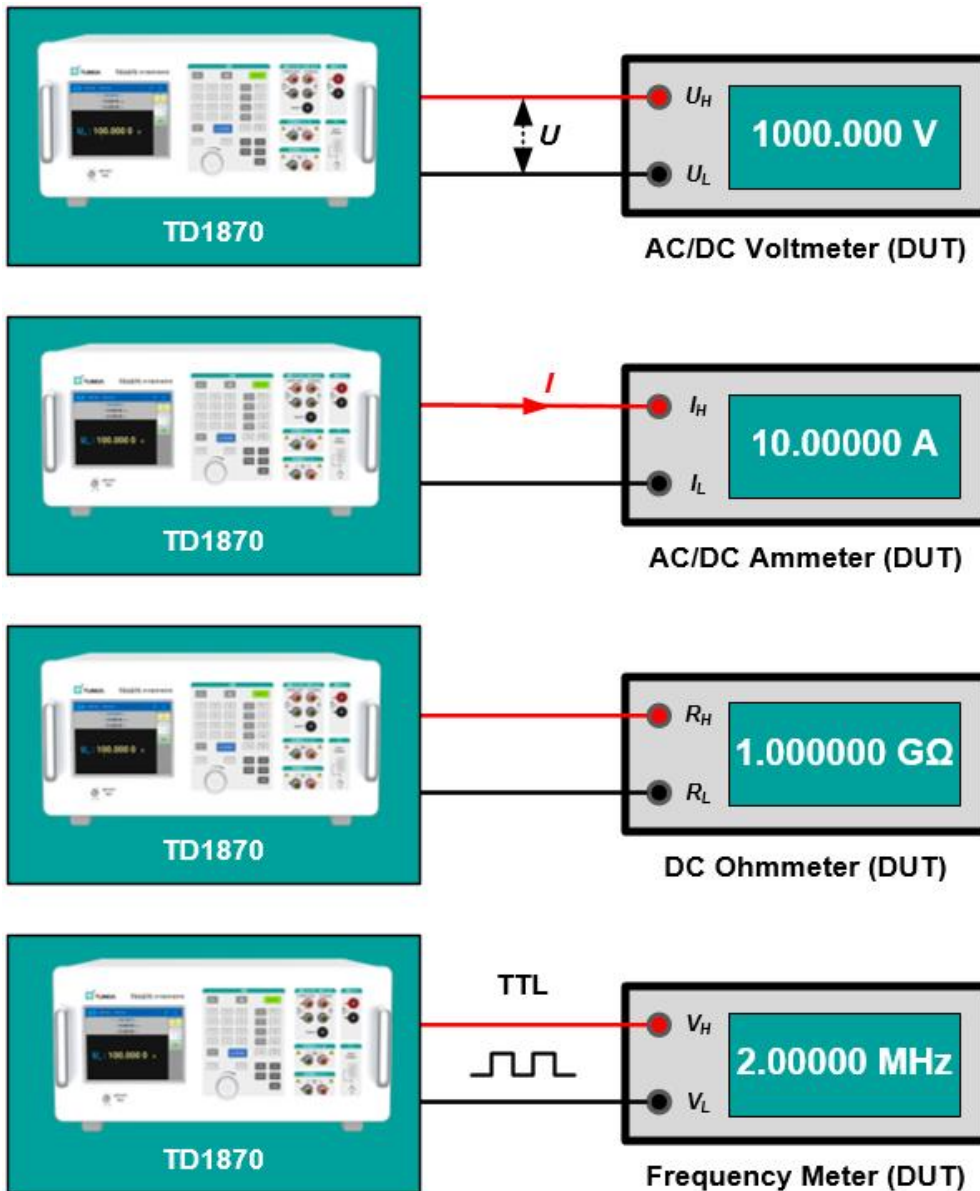
☆ Calibrate AC/DC electrical measuring instruments

- **DCV Output:** $\pm(0 \sim 1020\text{ V})$
- **DCI Output:** $\pm(0 \sim 20.5\text{ A})$
- **ACV Output:** $1\text{ mV} \sim 1020\text{ V}$ 、 $10\text{ Hz} \sim 500\text{ kHz}$
- **ACI Output:** $29\text{ }\mu\text{A} \sim 20.5\text{ A}$ 、 $10\text{ Hz} \sim 30\text{ kHz}$
- **RES Output:** $0\text{ }\Omega \sim 1100\text{ M}\Omega$
- **F Output:** $1\text{ Hz} \sim 2\text{ MHz}$
- Calibrate digital multimeter, AC/DC voltmeter, AC/DC ammeter, DC ohmmeter, frequency meter.

☆ Calibrate AC\DC power meters

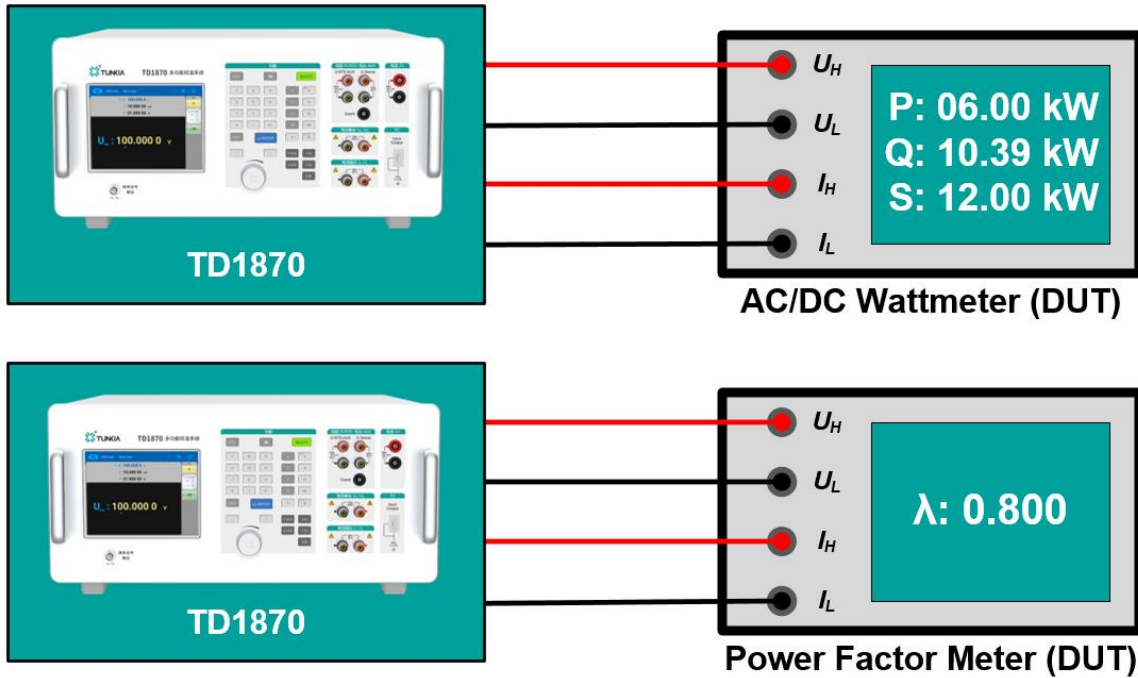

- Calibrate DC power meter, real power meter, phantom power meter, apparent power meter, power frequency phase meter and power factor meter.

☆ Calibrate temperature meters(optional)

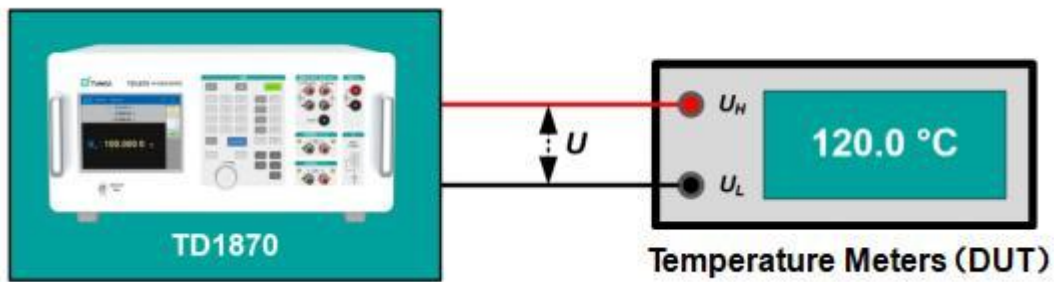

- Type of thermocouple (TC) output and measurement: B, E, J, K, N, R, S, T (8 types)
- Type of thermal resistance (RTD) output: Pt385-100Ω、Pt385-200Ω、Pt385-500Ω、Pt385-1000Ω、Cu50、Cu100 (6 types)

☆ Calibrate clamp ammeter (optional)

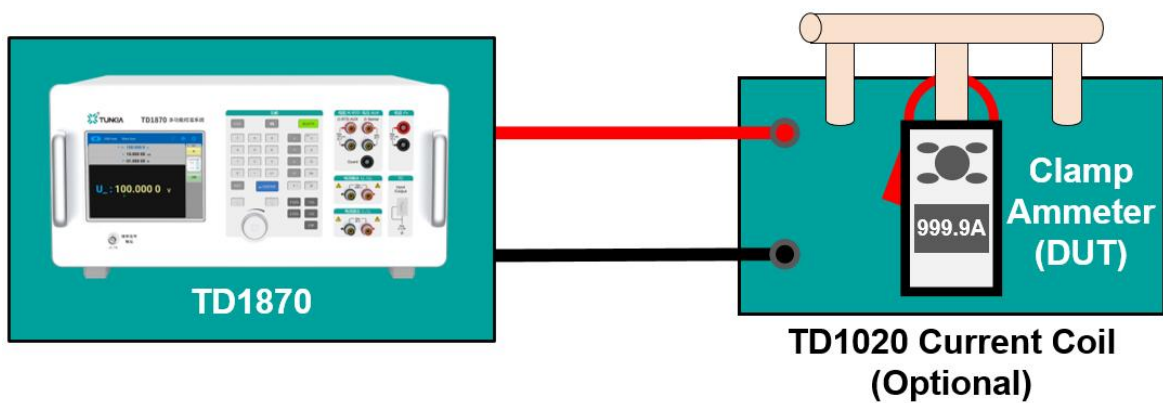

- Equivalent to 1000AT current through input 20A current to the 50T Coil, which is suitable for calibrating DC clamp meters.

4. Panel Features

☆ Front panel



Item	Description
1	LCD touchable screen.
2	Operation panel.
3	Pulse frequency output terminal.
4	Simulated DC resistance, RTD, Auxiliary voltage output terminals.
5	Simulated capacitance output terminals.
6	AC/DC voltage output terminals.
7	Thermocouple output terminals.
8	AC/DC current output terminals.

☆ Rear\Side Panel

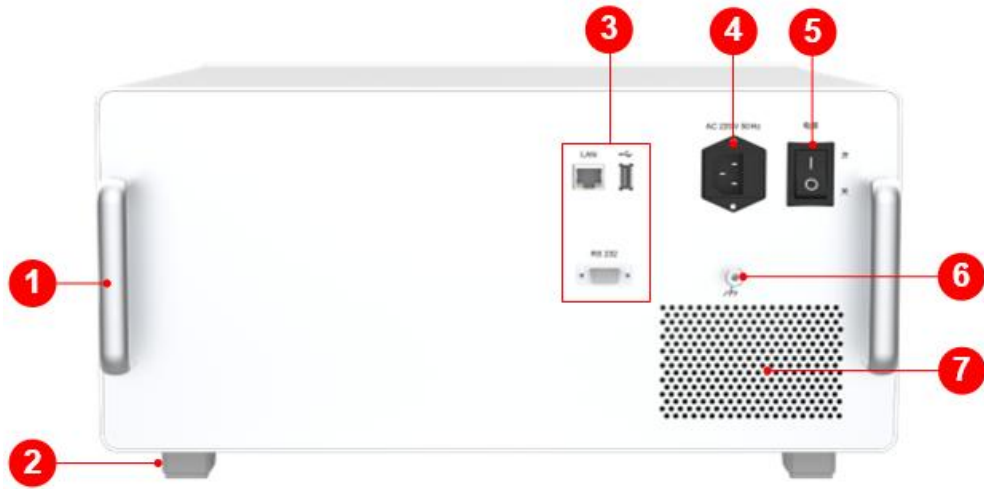

Rear Panel











Side Panel

Item	Description
1	Handle: used for carrying instruments
2	Foldable feet
3	USB/LAN/RS232
4	AC 220V power interface
5	power switch
6	Chassis ground binding post
7	Cooling vents

5. Characteristics

☆ Wide output range

	1n	1μ	1m	1	1k	1M	1G
DCV	1 mV  1020 V						
DCI	10 μA  20.5 A						
RES	1 Ω  1.1 GΩ						
ACV	1 mV  1020 V						
ACI	29 μA  20.5 A						
F₋	10 Hz  500 kHz						
F_~	1 Hz  2 MHz						
P_{U-I}	30 mV × 3 mA  1020 V × 20.5 A						

☆ High stability and accuracy

- The DC voltage stability is up to 4 ppm/24h.

☆ 4-terminals Simulated DC resistance

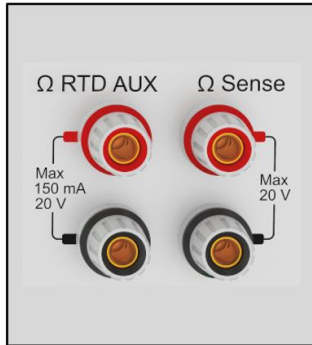

Figure(a) 4 terminals

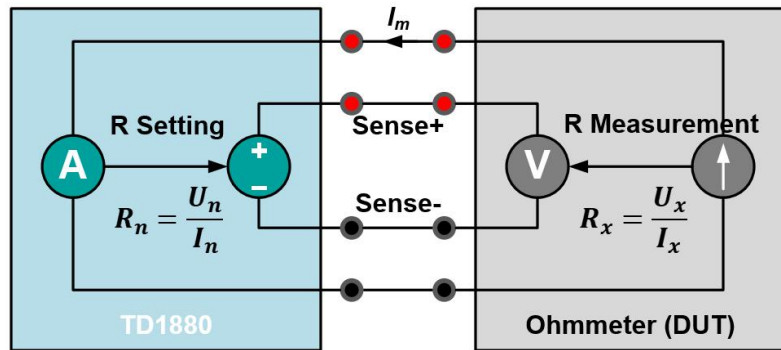

Figure(b) Wiring Diagram

- 2-terminals and 4-terminals resistance wiring mode. When calibrating the low value resistance, the four wire system wiring mode can effectively eliminate the measurement error caused by the resistance of the test lead and improve the measurement accuracy.
- Compared with the standard physical resistance box, the analog resistance output has the following characteristics:
 - ☑ Continuously adjustable, with better adjustment fineness and sensitivity
 - ☑ Smaller size and lighter weight
 - ☑ No influence of transfer switch error, residual resistance error and contact resistance error.

☆ Multiple output\adjustment methods

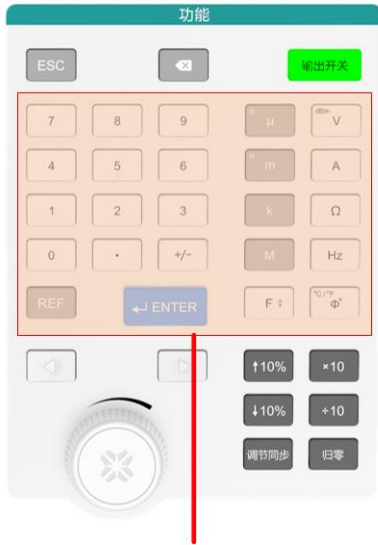

Figure (a) Keypad

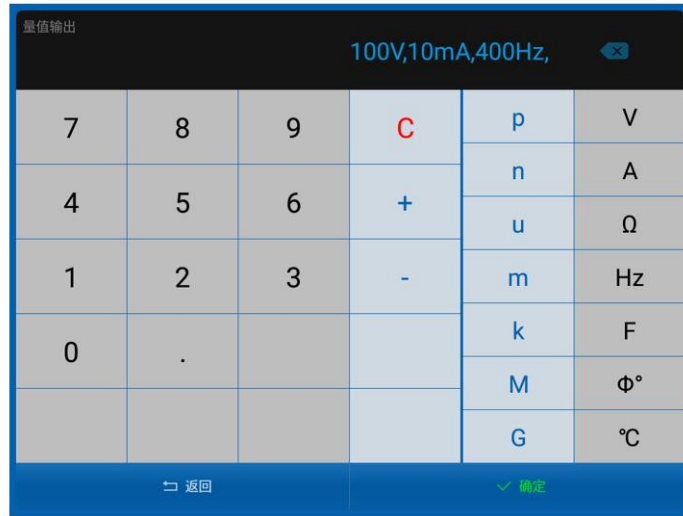

Figure (b) Touch Screen Output

- **“Direct output”** mode: the value output can be set directly by physical key or touch screen.

☆ Multiple output\adjustment methods



Rotary Knob

U : 100.0000 V

U : 100.1000 V

- “Rotary Knob” mode, User can set in clockwise direction or anticlockwise direction.



% Setting

Output

U_H 100.0000 V
U_L

U_H 110.0000 V
U_L

↑10% Output

U_H 90.0000 V
U_L

↓10% Output

U_H 1000.000 V
U_L

×10 Output

U_H 10.00000 V
U_L

÷10% Output

- Use the key $\uparrow 10\%$ 、 $\downarrow 10\%$ 、 $\times 10$ 、 $\div 10$ on the front panel, can realize the adjustment of the quantity value, and can also be used to perform the relevant test of linearity.

6. Specifications

6.1 DC Voltage Output

Range	Output Range	Accuracy ($T_{cal} \pm 5^{\circ}\text{C}$)		Stability ($T_{cal} \pm 1^{\circ}\text{C}$)	Resolution	Max Burden [Source internal resistance]
		$\pm(\text{ppm} \cdot \text{output} + \mu\text{V})$				
		90 days	1 year	24 hours		
300 mV	0~330.0000 mV	50 + 3	60 + 3	5 + 1	100 nV	[60 Ω]
3 V	0~3.300000 V	40 + 5	50 + 5	4 + 3	1 μV	20 mA
30 V	0~33.00000 V	40 + 50	50 + 50	4 + 30	10 μV	15 mA
300 V	30.0000 V~330.0000 V	45 + 500	55 + 500	4.5 + 300	100 μV	10 mA
1000 V	100.000 V~1020.000 V	45 + 1500	55 + 1500	4.5 + 900	1 mV	10 mA

- Manual or automatic range switch.
- Short-circuit and overload protection.

6.2 DC Current Output

Range	Output Range	Accuracy($T_{cal}\pm 5^{\circ}C$) $\pm(\text{ppm} \cdot \text{output} + \mu A)$		Resolution	Compliance Voltage (V)	Max Inductive Load
		90 days	1 year			
300 μA	0~330.000 μA	112 + 0.02	140 + 0.02	1 nA	11 V	400 μH
3 mA	0~3.30000 mA	72 + 0.04	90 + 0.04	10 nA	11 V	
30 mA	0~33.0000 mA	72 + 0.25	90 + 0.25	100 nA	9 V	
300 mA	0~330.000 mA	72 + 2.5	90 + 2.5	1 μA	7 V	
1 A	0~1.10000 A	200 + 44	250 + 40	10 μA	6 V	
3 A	1.00000 A~3.30000 A	240 + 44	300 + 40	10 μA	6 V	
20 A	3.0000 A~20.5000 A	480 + 500	600 + 500	100 μA	4 V	

- Manual or automatic range switch.
- Open-circuit and overload protection.
- Supports continuous and long-term output of current under full range.

6.3 Simulated DC resistance

Range	Output Range	Accuracy, ($T_{cal} \pm 5^{\circ}\text{C}$) $\pm(\text{ppm} \cdot \text{output} + \Omega)$		Resolution	Allowable Current
		90 days	1 year		
10 Ω	0 Ω ~11.00000 Ω	80 + 0.01	100 + 0.01	10 $\mu\Omega$	1 mA~150 mA
30 Ω	10.00000 Ω ~33.00000 Ω	80 + 0.015	100 + 0.015	10 $\mu\Omega$	1 mA~150 mA
100 Ω	30.0000 Ω ~110.0000 Ω	64 + 0.015	80 + 0.015	100 $\mu\Omega$	1 mA~80 mA
300 Ω	100.0000 Ω ~330.0000 Ω	64 + 0.02	80 + 0.02	100 $\mu\Omega$	1 mA~40 mA
1 k Ω	0.300000 k Ω ~1.100000 k Ω	64 + 0.02	80 + 0.02	1 m Ω	1 mA~20 mA
3 k Ω	1.000000 k Ω ~3.300000 k Ω	64 + 0.2	80 + 0.2	1 m Ω	0.1 mA~6 mA
10 k Ω	3.00000 k Ω ~11.00000 k Ω	64 + 0.1	80 + 0.1	10 m Ω	0.1 mA~2 mA
30 k Ω	10.00000 k Ω ~33.00000 k Ω	64 + 1	80 + 1	10 m Ω	10 μA ~0.6 mA
100 k Ω	30.0000 k Ω ~110.0000 k Ω	80 + 1	100 + 1	100 m Ω	10 μA ~0.2 mA
300 k Ω	100.0000 k Ω ~330.0000 k Ω	80 + 10	100 + 10	100 m Ω	1 μA ~60 μA
1 M Ω	0.300000 M Ω ~1.100000 M Ω	104 + 10	130 + 10	1 Ω	1 μA ~20 μA
3 M Ω	1.000000 M Ω ~3.300000 M Ω	104 + 150	130 + 150	1 Ω	0.25 μA ~6 μA
10 M Ω	3.00000 M Ω ~11.00000 M Ω	400 + 250	500 + 250	10 Ω	0.25 μA ~2 μA
30 M Ω	10.00000 M Ω ~33.00000 M Ω	650 + 2500	800 + 2500	10 Ω	25 nA~600 nA
100 M Ω	30.0000 M Ω ~110.0000 M Ω	3600 + 3000	4500 + 3000	100 Ω	25 nA~200 nA
300 M Ω	100.0000 M Ω ~330.0000 M Ω	3600 + 100000	4500 + 100000	100 Ω	2.5 nA~60 nA
1 G Ω	300.000 M Ω ~1100.000 M Ω	11000 + 480000	14000 + 480000	1 k Ω	1 nA~20 nA

- Manual or automatic range switch.
- Over-current and reverse connection protection.

6.4 AC Voltage Output

Range	Output Range	Frequency (Hz)	Accuracy, (T _{cal} ±5°C)		Resolution	Max Burden [Source internal resistance]
			±(%*output + μV)			
			90 days	1 year		
30 mV	1.0000 mV~ 33.0000 mV	10≤F≤45	0.10 + 20	0.12 + 20	100 nV	[10 Ω]
		45<F≤10k	0.08 + 20	0.10 + 20		
		10k<F≤20k	0.12 + 20	0.15 + 20		
		20k<F≤50k	0.16 + 20	0.20 + 20		
		50k<F≤100k	0.30 + 33	0.35 + 33		
		100k<F≤500k	0.72 + 60	0.90 + 60		
300 mV	30.000 mV~ 330.000 mV	10≤F≤45	0.04 + 18	0.05 + 18	1 μV	[60 Ω]
		45<F≤10k	0.024 + 18	0.03 + 18		
		10k<F≤20k	0.048 + 18	0.06 + 18		
		20k<F≤50k	0.064 + 30	0.08 + 40		
		50k<F≤100k	0.12 + 120	0.15 + 120		
		100k<F≤500k	0.28 + 300	0.35 + 300		
3 V	0.30000 V~ 3.30000 V	10≤F≤45	0.04 + 55	0.05 + 55	10μV	20 mA
		45<F≤10k	0.016 + 55	0.02 + 55		
		10k<F≤20k	0.048 + 55	0.06 + 55		
		20k<F≤50k	0.064 + 55	0.08 + 55		
		50k<F≤100k	0.12 + 180	0.15 + 180		
		100k<F≤500k	0.32 + 800	0.40 + 800		
30 V	3.0000 V~ 33.0000 V	10≤F≤45	0.04 + 750	0.05 + 750	100 μV	15 mA
		45<F≤10k	0.024 + 550	0.03 + 550		
		10k<F≤20k	0.048 + 550	0.06 + 550		
		20k<F≤50k	0.064 + 550	0.08 + 550		
		50k<F≤100k	0.16 + 1800	0.20 + 1800		
300 V	30.000 V~ 330.000 V	45≤F≤1k	0.024 + 2500	0.03 + 2500	1 mV	30 mA ^[1]
		1k<F≤10k	0.032 + 8000	0.04 + 8000		

		10k<F≤20k	0.048 + 8000	0.06 + 8000		
		20k<F≤50k	0.096 + 9000	0.12 + 9000		
		50k<F≤100k	0.192 + 80000	0.24 + 80000		
1000 V	300.00 V~ 1020.00 V	45≤F≤1k	0.024 + 15000	0.03 + 15000	10 mV	8 mA ^[2]
		1k<F≤5k	0.032 + 15000	0.04 + 15000		
		5k<F≤10k	0.032 + 15000	0.04 + 15000		

Note: [1] When the output frequency ≤ 3kHz, the maximum load is 30 mA; When the output frequency >3kHz, the maximum load is 5 mA.

[2] When the output frequency ≤ 3kHz, the maximum load is 8 mA; When the output frequency >3kHz, the maximum load is 3 mA.

- Manual or automatic range switch.
- Short-circuit and overload protection.

6.5 AC Current Output

Range	Output Range	Frequency (Hz)	Accuracy($T_{cal} \pm 5^{\circ}C$)		Resolution	Compliance Voltage (rms)	Max Inductive Load
			$\pm(\% \text{ output} + \mu A)$				
			90 days	1 year			
300 μA	29.000 μA ~ 330.000 μA	10 $\leq F \leq 20$	0.128 + 0.1	0.16 + 0.1	1 nA	7 V	200 μH
		20<F ≤ 45	0.096 + 0.1	0.12 + 0.1			
		45<F $\leq 1k$	0.064 + 0.1	0.08 + 0.1			
		1k<F $\leq 5k$	0.128 + 0.1	0.16 + 0.1			
		5k<F $\leq 10k$	0.24 + 0.2	0.3 + 0.2			
		10k<F $\leq 30k$	0.96 + 0.4	1.2 + 0.4			
3mA	0.30000 mA~ 3.30000 mA	10 $\leq F \leq 20$	0.128 + 0.1	0.16 + 0.1	10 nA	7 V	200 μH
		20<F ≤ 45	0.096 + 0.1	0.12 + 0.1			
		45<F $\leq 1k$	0.064 + 0.1	0.08 + 0.1			
		1k<F $\leq 5k$	0.128 + 0.2	0.16 + 0.2			
		5k<F $\leq 10k$	0.24 + 0.3	0.3 + 0.3			
		10k<F $\leq 30k$	0.96 + 0.5	1.2 + 0.5			
30 mA	3.0000 mA~ 33.0000 mA	10 $\leq F \leq 20$	0.096 + 2	0.12 + 2	100 nA	7 V	50 μH
		20<F ≤ 45	0.064 + 2	0.08 + 2			
		45<F $\leq 1k$	0.032 + 2	0.04 + 2			
		1k<F $\leq 5k$	0.064 + 2	0.06 + 2			
		5k<F $\leq 10k$	0.08 + 3	0.1 + 3			
		10k<F $\leq 30k$	0.24 + 4	0.3 + 4			
300 mA	30.000 mA~ 330.000 mA	10 $\leq F \leq 20$	0.096 + 20	0.12 + 20	1 μA	5 V	50 μH
		20<F ≤ 45	0.064 + 20	0.08 + 20			
		45<F $\leq 1k$	0.032 + 20	0.04 + 20			
		1k<F $\leq 5k$	0.048 + 40	0.06 + 40			
		5k<F $\leq 10k$	0.08 + 100	0.1 + 100			
		10k<F $\leq 30k$	0.24 + 200	0.3 + 200			
1 A	0.10000 A~ 1.10000 A	10 $\leq F \leq 45$	0.096 + 100	0.12 + 100	10 μA	5 V	2.5 μH
		45<F $\leq 1k$	0.032 + 80	0.04 + 80			

		1k<F≤5k	0.048 + 500	0.06 + 500			
		5k<F≤10k	0.08 + 1000	0.1 + 1000			
3 A	1.00000 A~ 3.30000 A	10≤F≤45	0.096 + 100	0.12 + 100	10μA	4 V	2.5μH
		45<F≤1k	0.032 + 80	0.04 + 80			
		1k<F≤5k	0.048 + 500	0.06 + 500			
		5k<F≤10k	0.08 + 2000	0.1 + 2000			
20 A	3.0000 A~ 20.5000 A	45≤F≤100	0.048 + 1500	0.06 + 1500	100μA	3 V	1μH
		100<F≤1k	0.064 + 1500	0.08 + 1500			
		1k<F≤5k	0.096 + 3000	0.12 + 3000			

- Manual or automatic range switch.
- Open-circuit and overload protection.
- Supports continuous and long-term output of current under full range.

6.6 Sinusoidal Wave Frequency Output

Range	Resolution	Accuracy ($T_{cal} \pm 5^{\circ}C$)
$10.00000 \text{ Hz} \leq F \leq 99.99999 \text{ Hz}$	10 μ Hz	$\pm 0.005\%$
$100.0000 \text{ Hz} \leq F \leq 999.9999 \text{ Hz}$	0.1 mHz	$\pm 0.005\%$
$1.000000 \text{ kHz} \leq F \leq 9.999999 \text{ kHz}$	1 mHz	$\pm 0.005\%$
$10.00000 \text{ kHz} \leq F \leq 99.99999 \text{ kHz}$	10 mHz	$\pm 0.005\%$
$100.0000 \text{ kHz} \leq F \leq 500.0000 \text{ kHz}$	0.1 Hz	$\pm 0.005\%$

6.7 Phase and Power Factor Output

Phase		Accuracy($T_{cal} \pm 5^{\circ}C$)					
		10~20Hz	20~45Hz	45~1kHz	1k~5kHz	5k~10kHz	10k~30kHz
φ		0.1°	0.1°	0.05°	0.5°	1.0°	2.0°
phase (φ)	Power factor (λ)	Power accuracy caused by phase ^[3]					
		10~20Hz	20~45Hz	45~1kHz	1k~5kHz	5k~10kHz	10k~30kHz
0°	1.00000	0.000%	0.000%	0.000%	0.004%	0.015%	0.061%
10°	0.98481	0.031%	0.031%	0.015%	0.158%	0.323%	0.676%
20°	0.93969	0.064%	0.064%	0.032%	0.321%	0.650%	1.331%
30°	0.86603	0.101%	0.101%	0.050%	0.508%	1.023%	2.076%
40°	0.76604	0.147%	0.147%	0.073%	0.736%	1.480%	2.989%
50°	0.64279	0.208%	0.208%	0.104%	1.044%	2.095%	4.220%
60°	0.50000	0.302%	0.302%	0.151%	1.515%	3.038%	6.106%
70°	0.34202	0.480%	0.480%	0.240%	2.401%	4.810%	9.649%
80°	0.17365	0.990%	0.990%	0.495%	4.953%	9.913%	19.853%
90°	0.00000	—	—	—	—	—	—

Note: [1] Phase resolution: 0.001°; [2] Power factor resolution: 0.000 01;

[3] Other power factor accuracy calculation formula: $U_{\lambda} = [1 - \cos(\varphi + \Delta\varphi) / \cos\varphi] \times 100\%$

6.8 AC/DC Power Output

Frequency (Hz)	Voltage Range (U)	Current Range (I)	Phase Range (φ)	Power Factor Range ^[2] (λ)
DC	0~±1020 V	0~±20.5 A	—	—
10~45	30 mV~33 V	3 mA~3.3 A	0.000°~359.999°	-1~0~1
45~1k	30 mV~1020 V	3 mA~20.5 A	0.000°~359.999°	-1~0~1
1k~5k	3 V~1020 V	30 mA~3.3 A	0.000°~359.999°	-1~0~1
5k~10k	3 V~1020 V	30 mA~3.3 A	0.000°~359.999°	-1~0~1
10k~30k	3 V~330 V	30 mA~330 mA	0.000°~359.999°	-1~0~1

Note: [1] DC power output range: combination of DC voltage and DC current output.

[2] AC power output range: combination of AC voltage, AC current and phase regulation output. See the table for specific range.

[3] Please refer to the calculation formula for the technical indicators of AC and DC power measurement uncertainty: $U_p = \sqrt{U_U^2 + U_I^2 + U_\lambda^2}$, U_U is the accuracy of voltage measurement, U_I is the accuracy of current measurement, U_λ is the accuracy caused by power factor.

6.9 Pulse Frequency Output

Range ^[1]	Resolution	Accuracy, (T _{cal} ±5°C) ±(ppm*RD + μHz)	Shake
1.000 00 Hz ≤ F ≤ 9.999 99 Hz	10 μHz	20 + 20	<20 ns
10.000 0 Hz ≤ F ≤ 99.999 9 Hz	0.1 mHz		
100.000 Hz ≤ F ≤ 999.999 Hz	1 mHz		
1.000 00 kHz ≤ F ≤ 9.999 99 kHz	10 mHz		
10.000 0 kHz ≤ F ≤ 99.999 9 kHz	0.1 Hz		
100.000 kHz ≤ F ≤ 999.999 kHz	1 Hz		
1.000 00 MHz ≤ F ≤ 2.000 00 MHz	10 Hz		

Note [1]: The output type is TTL level.

6.10 Thermocouple Output and Measurement (optional)

Type ^[1]	Output Range ^{[2] [3]}	Accuracy ($T_{cal} \pm 5^{\circ}\text{C}$) ^[4] ($^{\circ}\text{C}$)	
		90 days	1 year
B	410°C ~ 600°C	0.33	0.35
	600°C ~ 900°C	0.26	0.28
	900°C ~ 1800°C	0.20	0.22
E	-200°C ~ 0°C	0.09	0.10
	0°C ~ 600°C	0.06	0.08
	600°C ~ 1000°C	0.08	0.10
J	-200°C ~ -100°C	0.12	0.13
	-100°C ~ 750°C	0.07	0.08
	750°C ~ 1200°C	0.08	0.10
K	-200°C ~ -100°C	0.15	0.16
	-100°C ~ 1000°C	0.08	0.10
	1000°C ~ 1370°C	0.10	0.12
N	-200°C ~ -100°C	0.21	0.22
	-100°C ~ 400°C	0.07	0.09
	400°C ~ 1300°C	0.09	0.11
R	-50°C ~ 50°C	0.36	0.38
	50°C ~ 300°C	0.25	0.27
	300°C ~ 1000°C	0.18	0.20
	1000°C ~ 1750°C	0.18	0.20
S	-50°C ~ 50°C	0.36	0.38
	50°C ~ 300°C	0.25	0.27
	300°C ~ 1000°C	0.18	0.20
	1000°C ~ 1750°C	0.21	0.23
T	-200°C ~ 100°C	0.13	0.15
	-100°C ~ 0°C	0.08	0.11
	0°C ~ 400°C	0.06	0.08

Note [1]: Use external compensation, S, R, B, K, N, E, J, T conform to ITS-90 international temperature standard;

Note [2]: Temperature resolution: 0.01 ° C;

Note [3]: Internal resistance of output source: 10 Ω;

Note [4]: The thermocouple error is not included.

- Voltage output/measurement range: -10 mV~ 80 mV
- 7 digits decimal display
- Ripple coefficient: <0.5%

6.11 RTD Output(optional)

Type	Output Range ^[1]	Accuracy, (T _{cal} ±5°C), °C	
		90 days	1 year
Pt385, 100 Ω	-200°C ~ 850°C	0.04	0.05
Pt385, 200 Ω	-200°C ~ 320°C	0.30	0.35
	320°C ~ 850°C	0.35	0.40
Pt385, 500 Ω	-200°C ~ -30°C	0.04	0.05
	-30°C ~ 850°C	0.13	0.15
Pt385, 1000 Ω	-200°C ~ 850°C	0.07	0.09
Cu50	-50°C ~ 150°C	0.07	0.09
Cu100	-50°C ~ 150°C	0.04	0.05

Note[1]: Resolution: 0.001°C

7. General Specifications

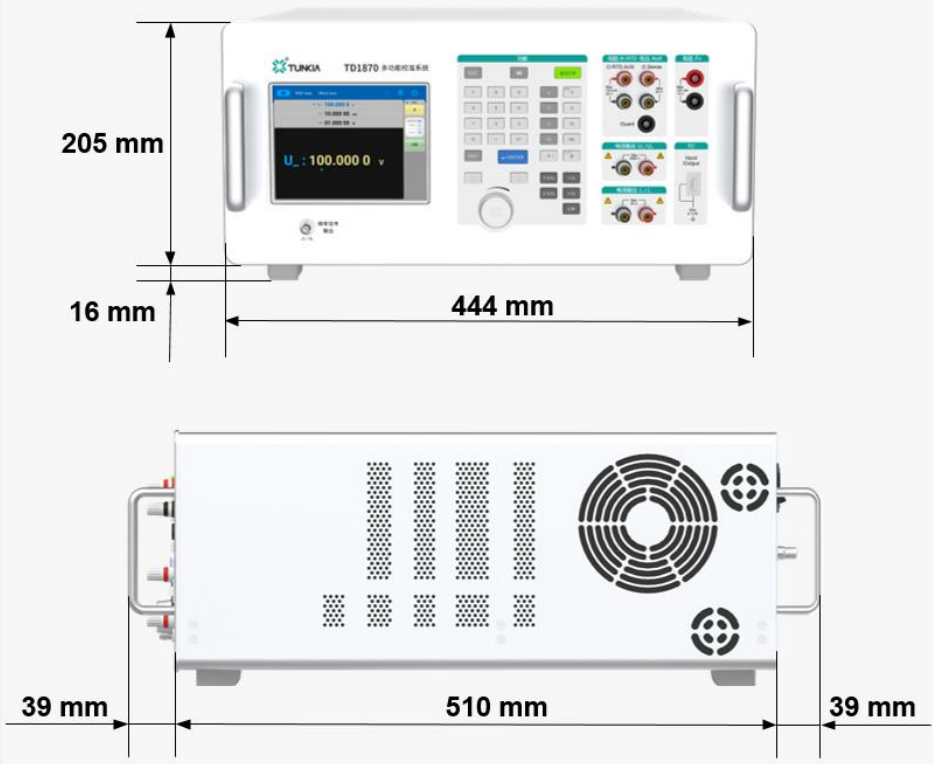
Power supply	AC (220±22) V, (50±2) Hz
Maximum power consumption	550 VA
Warm up time	Twice the time since last warmed up, to a maximum of 30 minutes.
Temperature performance	Operating temperature: 0°C ~ 50°C Calibration temperature: 15°C ~ 35°C Storage temperature: -20°C~70°C
Humidity performance	Operating humidity: <80% @ 30°C, <70% @ 40°C, <40% @ 50°C Storage humidity: <95%, No condensation
Communication interface	RS232×1、USB×1、LAN×1
Dimensions	444 mm(W)× 510 mm (D) × 205 mm (H), Handles and feet excluded.
	

8. Ordering Information

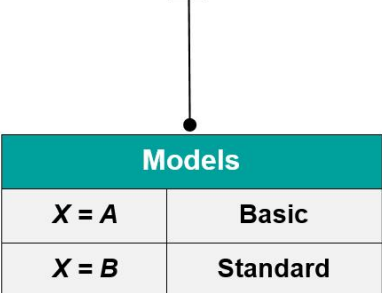
<p>TD1870 X</p>  <table border="1" style="margin-left: auto; margin-right: auto;"> <thead> <tr> <th colspan="2">Models</th> </tr> </thead> <tbody> <tr> <td>X = A</td> <td>Basic</td> </tr> <tr> <td>X = B</td> <td>Standard</td> </tr> </tbody> </table>	Models		X = A	Basic	X = B	Standard	Function	TD1870A	TD1870B
	Models								
	X = A	Basic							
	X = B	Standard							
	AC/DC voltage source (U)	★	★						
	AC/DC current source (I)	★	★						
	Simulated DC resistance (R)	★	★						
	AC/DC power output (P)	★	★						
	Square wave frequency output (F _r)	★	★						
Simulated TC output & TC measurement (TC)	—	★							
Simulated RTD output (RTD)	—	★							